

## Product Datasheet



The global certified APD-110-C is a dual stage high efficiency smart LED driver. 10kV surge protection level, 100khour long life and 7-year warranty provide high confidence to luminaire users. It supports not only traditional 0-10V control, but also D4i smart protocols with NFC programmability. All around protections including digital OTP (internal and external by NTC) with auto-recovery secure 24hour non-stop operation for luminaires.

- Street
- Flood
- Tunnel
- Shoe box
- Architectural



- Features ..... 2
- Model List ..... 2
- Technical Data ..... 2
- Safety/EMC Compliance ..... 3
- Dimming ..... 4
- Programming ..... 5
- Lifetime vs. Case Temperature ..... 6
- Power Factor vs. Load ..... 6
- THD vs. Load ..... 7
- Efficiency vs. Load ..... 7
- Inrush Current ..... 8
- Dielectric Strength ..... 8
- Packaging Information ..... 9
- Mechanical Design and Tc Point ..... 10
- Output Operation Range ..... 11
- Revision History ..... 12

### 110W, DPAC™ Tech, D4i and NFC Programmable LED Driver

#### ■ Features

- Supply Voltage: 176-264Vac
- Great Surge Immunity 10kV
- **DPAC™ Tech (D4i Plus 0-10V Combo)**
- D4i/DALI2.0 Comply with IEC62386-101,102,150,207,250,251,252,253
- Integrated 16Vdc Bus Power Supply
- $\pm 1\%$  Energy Report Accuracy
- Dim Off with 0.5W Standby Power
- 24V 3W (10W Transient Peak) Aux-Power
- 100,000Hour Life @ Tc=75°C & 7 Year Warranty @ Tc<=75°C
- +/-2% Output Current Accuracy
- Airset™ NFC Programmability
- Class II and Class I Combo
- Safety according to EN 61347-1, 61347-2-13, 62384

#### ■ Model List

Model Number	Input Voltage Range	Output Power	Output Voltage	Full Power Settable Current Min	Full Power Settable Current Max	Dimming	Certification
APD-110-C105-ARE	176-264Vac	110 W	63-169Vdc	650mA	1050mA	D4i&0-10V Combo	ENEC/CB/EL/CE /RCM
APD-110-C105-ERE	176-264Vac	110 W	63-169Vdc	650mA	1050mA	0-10V	
APD-110-C070-ARE	176-264Vac	110 W	94-220Vdc	500mA	700mA	D4i&0-10V Combo	
APD-110-C070-ERE	176-264Vac	110 W	94-220Vdc	500mA	700mA	0-10V	

- Note:** 1. For –ARE model, D4i priority is higher than 0-10V if both dimming control signals exist.  
2. See the **Output Operation Range Section** for details.

#### ■ Technical Data

Input Voltage	176-264Vac
Input Frequency	47~63Hz
Power Factor	>0.9@60-100%load, refer to PF vs. Load curve
THD	<15%@60-100%load, refer to THD vs. Load curve
Input Current	0.85Amax@220Vac & Full-Load
Inrush Current	See Inrush Current Section in the datasheet
Leakage Current	0.7mA max @240Vac 50/60Hz, IEC60598-1
Input Under Voltage	Shut down and auto-restart
Surge Protection	Line to line 6kV, line to ground 10kV, IEC 61000-4-5
Current Accuracy	$\pm 2\%$ lo for programmable model, $\pm 5\%$ lo for non-programmable model
Ripple Current	lp-p:5%lo max
Setup Time	1.2s max
Overshoot	10% lo max & LED Load

**110W, DPAC™ Tech, D4i and NFC Programmable LED Driver**

Output Over Voltage	120% Vomax, typ.
Short Circuit	Auto recovery. The output recovers when short is removed.
Over Temperature	Lower the output current when $T_c \geq 105 \pm 10^\circ\text{C}$ ; Auto Recovery When $T_c \leq 70 \pm 10^\circ\text{C}$
Auxiliary Power (Vaux)	24V+/-5%, 3W (10W Transient Peak)
Operating Temperature	Case Temperature $T_c = -40^\circ\text{C} \sim +85^\circ\text{C}$ ; 10%RH ~ 100%RH
Storage Temperature	$-40^\circ\text{C} \sim +85^\circ\text{C}$ ; 5%RH ~ 100%RH
MTBF	$\geq 320,000$ hours, $75^\circ\text{C}$ case temperature (MIL-HDBK-217F)
Lifetime	$\geq 100,000$ hours, $75^\circ\text{C}$ case temperature, refer to life vs. $T_c$ curve
Case Temperature	$85^\circ\text{C}$ max, marked in the $T_c$ point of label
Dimension	133.0 x 77.0 x 40.0 by mm
Net Weight	550g
Packing	See Package Information Section in the datasheet

Notes: Unless specified, all the test results are measured in  $25^\circ\text{C}$  room temperature.

## ■ Safety/EMC Compliance

Safety Standard	Description
UL8750	Light emitting diode(LED) equipment for use in lighting products
UL1012	Power units other than class 2
IEC 61347-1	Lamp control gear Part 1: general and safety requirements
IEC 61347-2-13	Lamp control gear Part 2-13: particular requirement for d.c. or a.c. supplied electronic control gear for LED modules
EMI Standards	Description
IEC 55015	Conducted emission test & radiated emission test
IEC 61000-3-2	Harmonic current emissions; Class C
IEC 61000-3-3	Voltage fluctuations & flicker
FCC Part 15	ANSI C63.4:2009 Class B
EMS Standards	Description
IEC 61000-4-2	Electrostatic discharge (ESD): 8 kV air discharge, 4 kV contact discharge
IEC 61000-4-3	Radio frequency electromagnetic field susceptibility test (RS)
IEC 61000-4-4	Electrical fast transient (EFT)
IEC 61000-4-5	Surge immunity test
IEC 61000-4-6	Conducted radio frequency disturbances test (CS)
IEC 61000-4-8	Power frequency magnetic field test
IEC 61000-4-11	Voltage dips
IEC 61547	Electromagnetic immunity requirements applies to lighting equipment

■ Dimming

D4i Related Parameter	Min.	Typ.	Max.
DALI Interface Standard	IEC62386-101,102,150,207,250,251,252,253		
Dimming Range	10%	-	100%
DA1,DA2 High Level	9.5V	16V	22.5V
DA1,DA2 Low Level	-6.5V	0	6.5V
DA1,DA2 Current	0		2mA
Bus Power Supply Voltage	12Vdc	16Vdc	20Vdc
Bus Power Supply Current	52mA	-	60mA
Auxiliary Power Voltage	21.6V	24V	26.4V
Auxiliary Power	3W	-	4W
Auxiliary Power Endurance @6W	3.8ms/6ms	-	4.5ms/6ms
Auxiliary Power Endurance @10W	1.8ms/6ms	-	2.2ms/6ms
Bus Power Supply Current	52mA	-	60mA
0-10V Related Parameter	Min.	Typ.	Max.
Vdim Sourcing Current	100uA	150uA	200uA
Vdim Allowed Input Voltage	-20 V		20 V
0-10V Dimming Range	10% (Vdim=1V)	Linear	100% (Vdim=9~10V)
Dim off threshold	0.4V	0.5V	0.6V
Dim on threshold	0.6V	0.7V	0.8V

- Dimming Curve

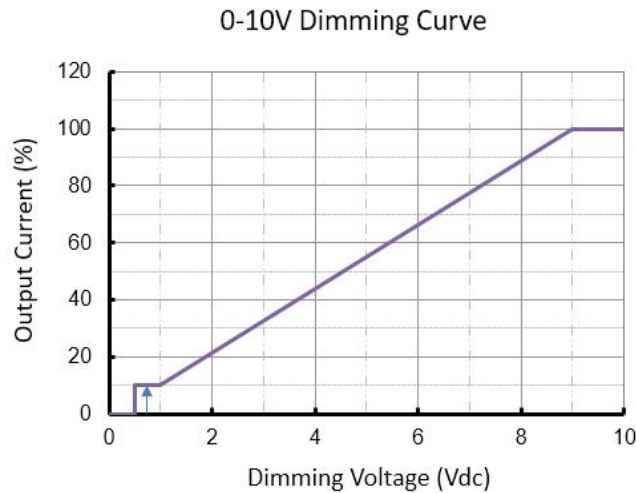

## ■ Programming

### - NFC Programming by PC/Laptop



- Download PC Software at <https://www.upowertek.com/download-2/>
- Click Upowertek Programming Utility.exe
- The GUI start and notify you the programming mode (cable programming or NFC programming)
- Click "NFC" button if it's not NFC programming mode.

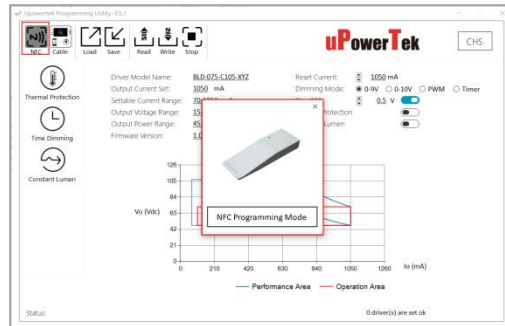
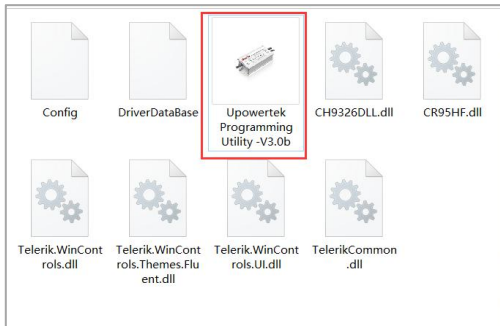

### - NFC Programming by Smartphone

- Download Android APP at <https://www.upowertek.com/download-2/>
- Only available on Android cellphone (iPhone is not supported)
- The cellphone should have NFC function and make sure it is enabled.

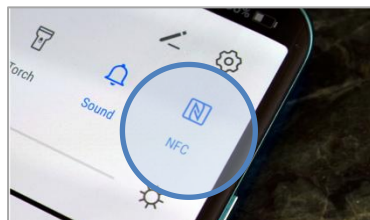

- Turn on NFC switch of cellphone, then open the APP by icon below.



uPowerTek  
Airset

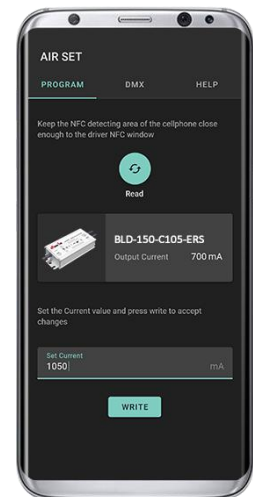

■ Lifetime vs. Case Temperature

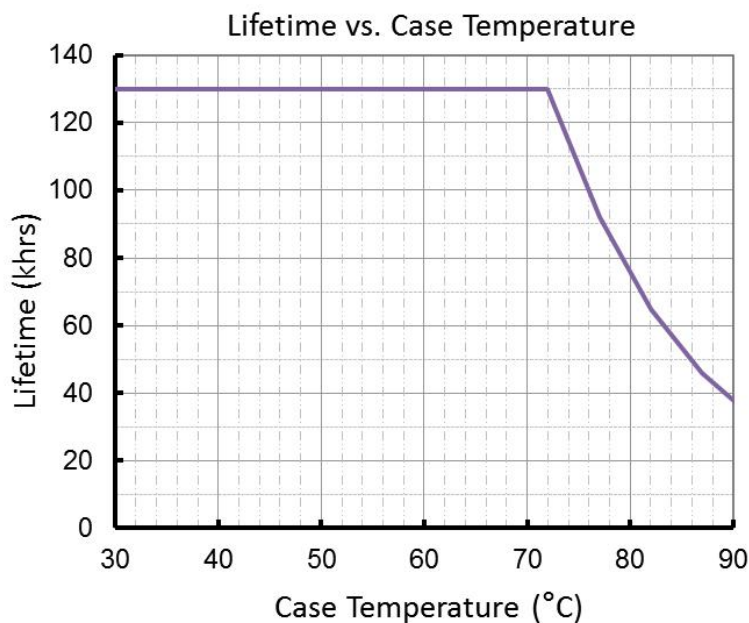

(End of Life: Maximum Failure Rate=10%)

■ Power Factor vs. Load

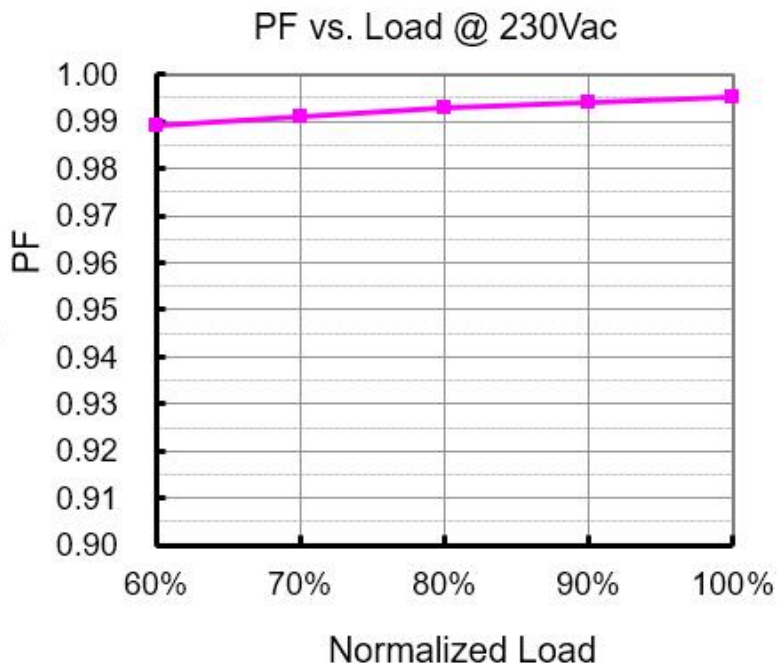

## ■ THD vs. Load

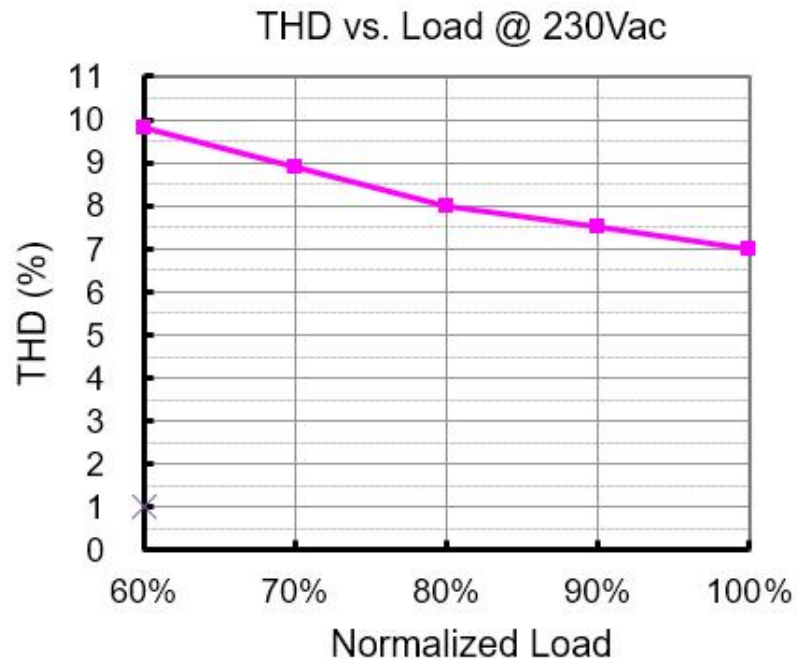

## ■ Efficiency vs. Load

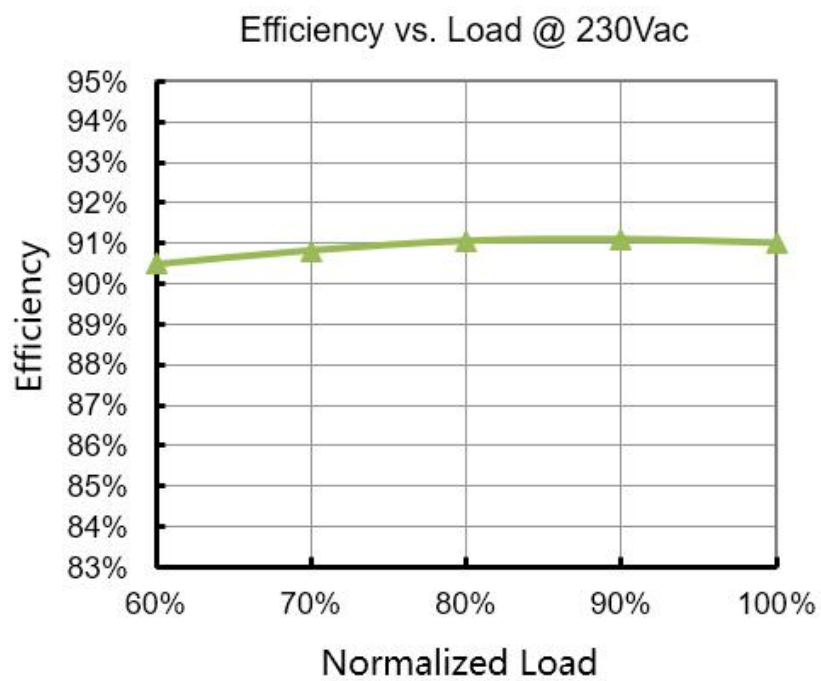

## ■ Inrush Current

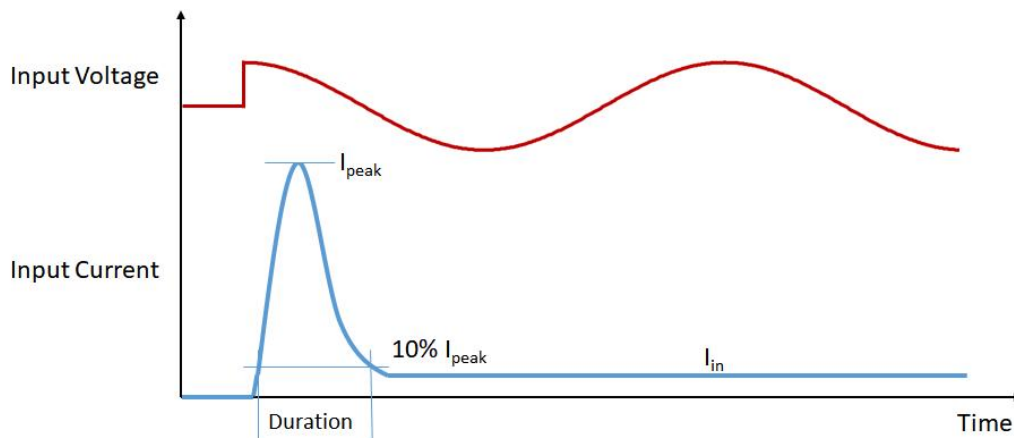

Input Voltage	$I_{peak}$	Duration
230Vac	62.8A	809us

Please contact with us for MCB calculation and waveforms.

## ■ Dielectric Strength

Unit: Vac	Input	Output	NTC/Dimming/Vaux (SELV)	Case/PE
Input	-	3750	3750	1554
Output	3750	-	1554	1554
Dimming/Vaux/NTC (SELV)	3750	1554	-	1554
Case/PE	1554	1554	1554	-



## ■ Packaging Information

Typical Carton Dimension(L×W×H)	360×300×180 mm
Shield Board 1	7pcs/carton
Positioning plate	2pcs/carton
Shield Board	2pcs/carton
LED Drivers	24pcs/carton
Net Weight	13.3kg/carton
Gross Weight	14.0 kg/carton

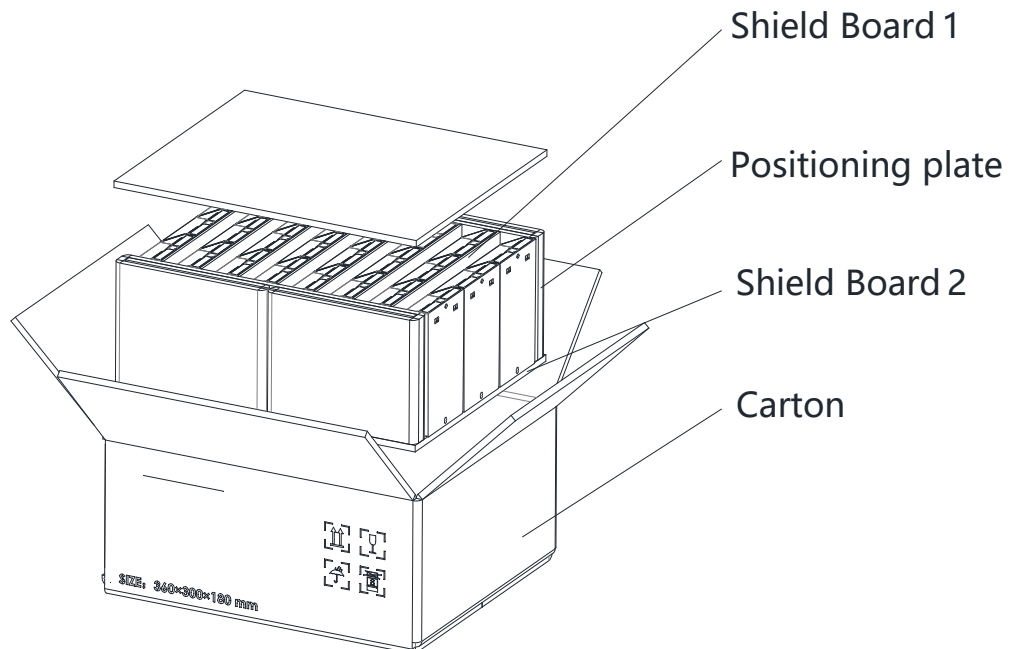

## Mechanical Design and Tc Point

- APD-110-Cxxx-ARE

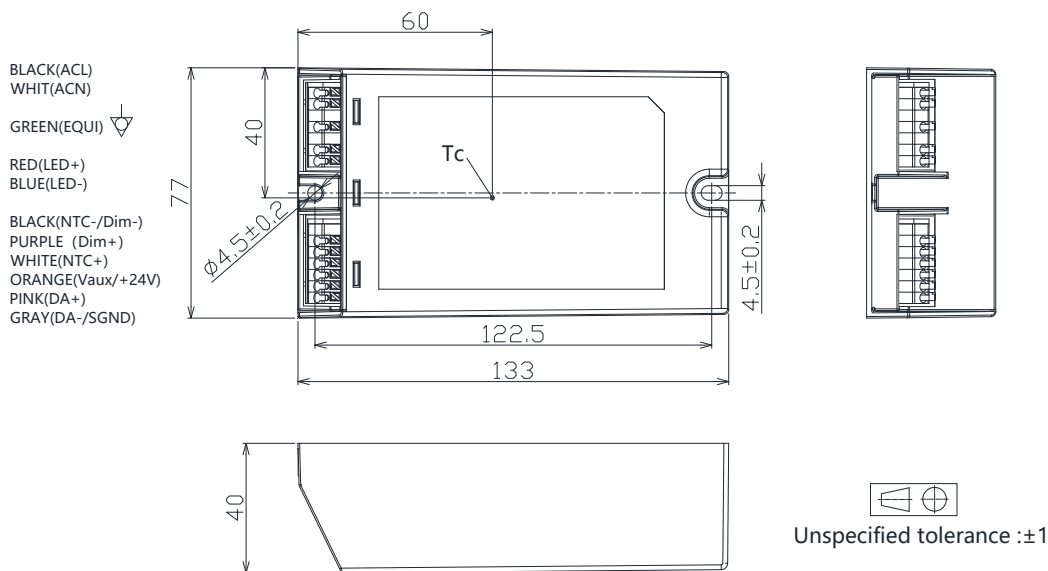

- APD-110-Cxxx-ERE

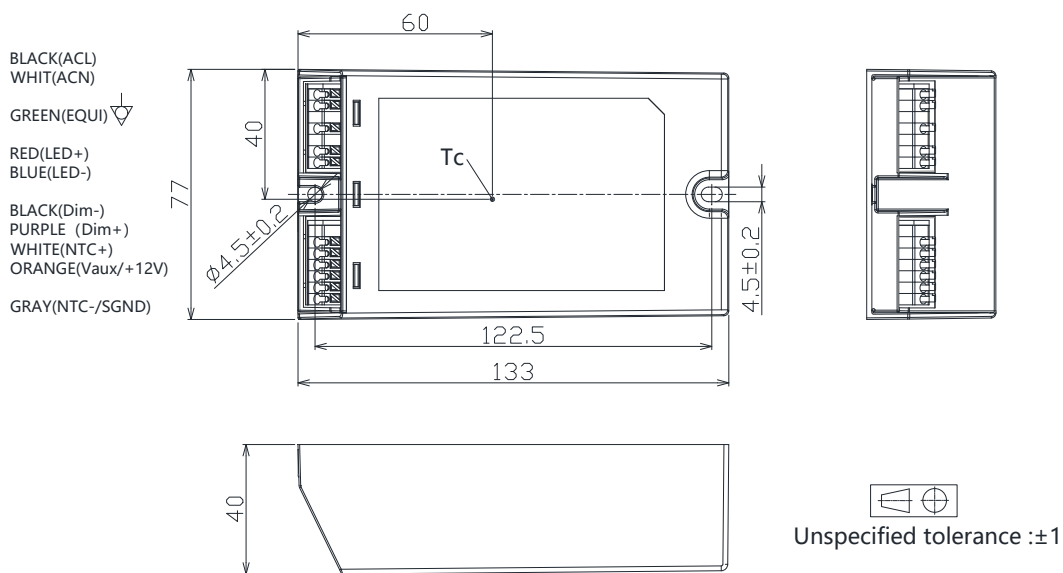

## 110W, DPAC™ Tech, D4i and NFC Programmable LED Driver

## ■ Output Operation Range

Model	Typical Set Output Current (mA)	Max Output Power (W)	Output Voltage Min (V)	Output Voltage Max(V)	Minimum Dimming Current (mA)
-C105	1050	110	63	105	105
	1000	110	66	110	100
	950	110	69	116	95
	900	110	73	122	90
	850	110	78	129	85
	800	110	83	138	80
	750	110	88	147	75
	700	110	94	157	70
	650	110	102	169	65
	600	102	102	169	65
	550	93	102	169	65
	500	85	102	169	65
	450	76	102	169	65
	400	68	102	169	65
	350	59	102	169	65
	300	51	102	169	65
	...	...	...	...	...
	70	12	102	169	70
Model	Typical Set Output Current (mA)	Max Output Power (W)	Output Voltage Min (V)	Output Voltage Max(V)	Minimum Dimming Current (mA)
-C070	700	110	94	157	70
	650	110	102	169	65
	600	110	110	183	60
	550	110	120	200	55
	500	110	132	220	50
	450	99	132	220	50
	400	88	132	220	50
	350	77	132	220	50
	300	66	132	220	50
	...	...	...	...	...
	50	11	132	220	50

**■ Revision History**

Revision	Date	Contents
A	2022-07-22	First Release
B	2022-09-21	C070 Model Added
C	2022-10-27	1. Mechanical design and Tc point updated. 2. Packaging information updated.
D	2023-07-14	1. Update leakage current